

# DCC Series

For DC-DC Converter

1/8 Bricks

Quarter Bricks

Half Bricks

**ALPHA**

# ALPHA

1/8 Bricks  
Width .9"  
Length 2.9"

# DCC2359L

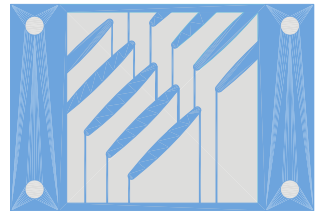

DIM

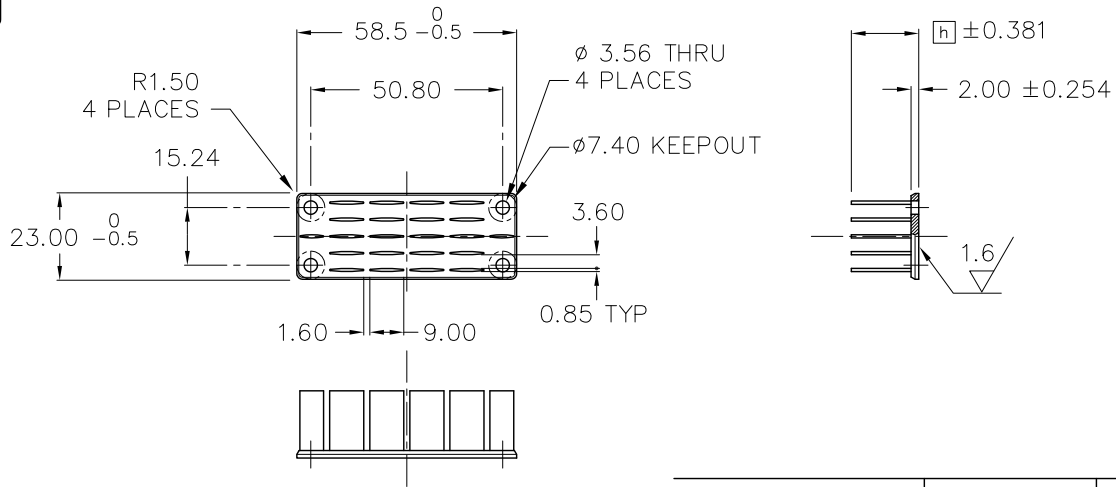

HEAT SINK  
MATERIAL : A 6063  
FINISH : BLACK ANODIZE

MODEL	HEIGHT $h$	WEIGHT (grams)
DCC2359L-6B	6.10	8.3
DCC2359L-11B	10.80	10.0
DCC2359L-18B	17.80	12.4
DCC2359L-23B	22.80	14.1

Dimensions : mm

DATA

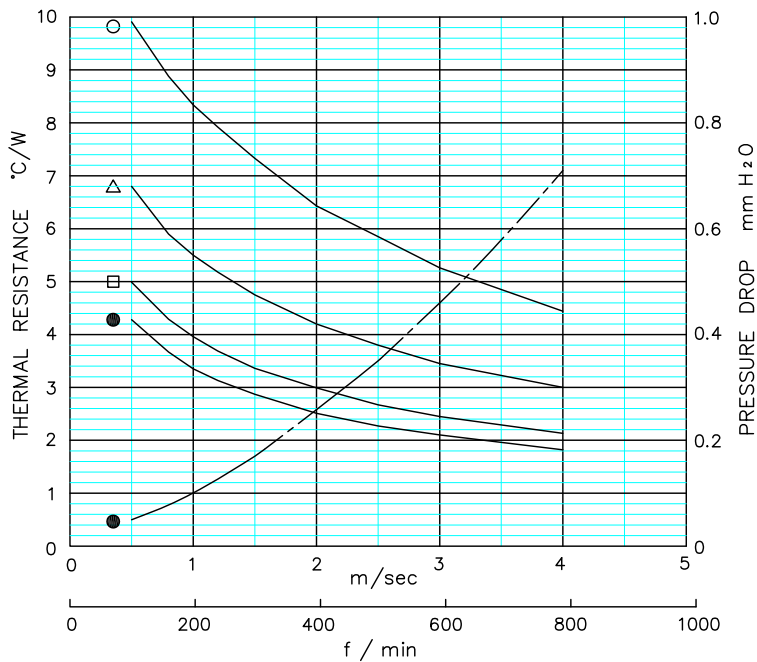

AIR VELOCITY: DUCTED CONDITION

- DCC2359L-6B
- △ DCC2359L-11B
- DCC2359L-18B
- DCC2359L-23B

● DUCTED CONDITION  
 THERMAL RESISTANCE ———  
 PRESURE DROP - - -

■ BASED ON ALPHA'S STANDARD TEST PROCEDURE.  
 REFER TO TECHNICAL INFORMATION.

Alpha Company Ltd.

256-1 UEDA, NUMAZU-CITY SHIZUOKA-PREF., JAPAN  
 PHONE +81(55)966 0789  
 FAX +81(55)966 9192  
 E mail : alpha@micforg.co.jp  
 URL : <http://www.micforg.co.jp>

Alpha Novatech, Inc. - a subsidiary of Alpha Company.

473 Sapena Ct. #12 Santa Clara, CA 95054 USA  
 PHONE +1(408)567-8082  
 FAX +1(408)567-8053  
 E mail : sales@alphanovatech.com  
 URL : <http://www.alphanovatech.com>

# ALPHA

1/8 Bricks  
Width 2.3"  
Length .9"

# DCC5923L

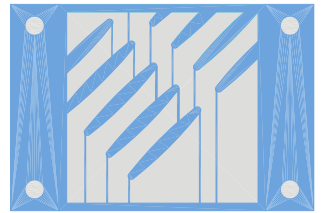

DIM

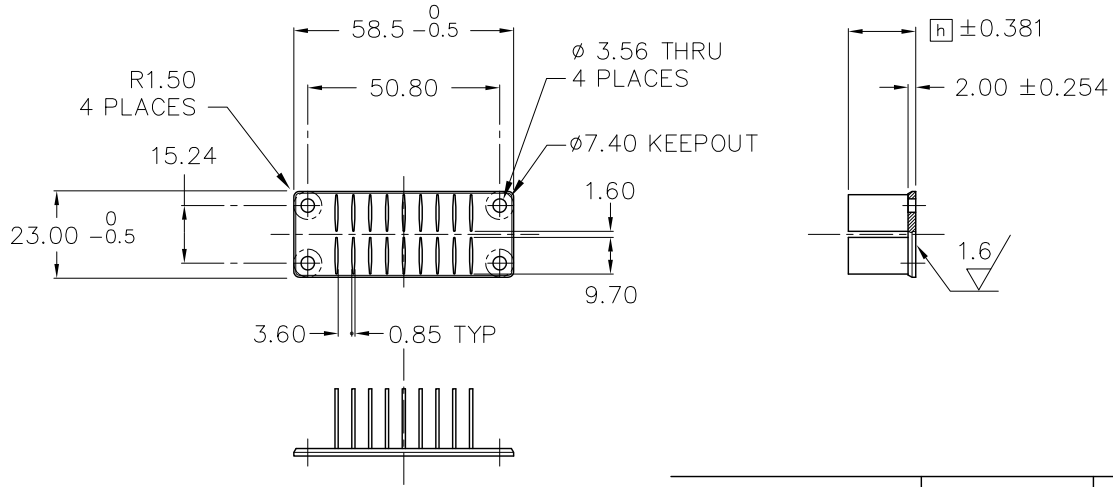

HEAT SINK  
MATERIAL : A 6063  
FINISH : BLACK ANODIZE

MODEL	HEIGHT $h$	WEIGHT (grams)
DCC5923L-6B	6.10	8.1
DCC5923L-11B	10.80	9.6
DCC5923L-18B	17.80	11.8
DCC5923L-23B	22.80	13.4

Dimensions : mm

DATA

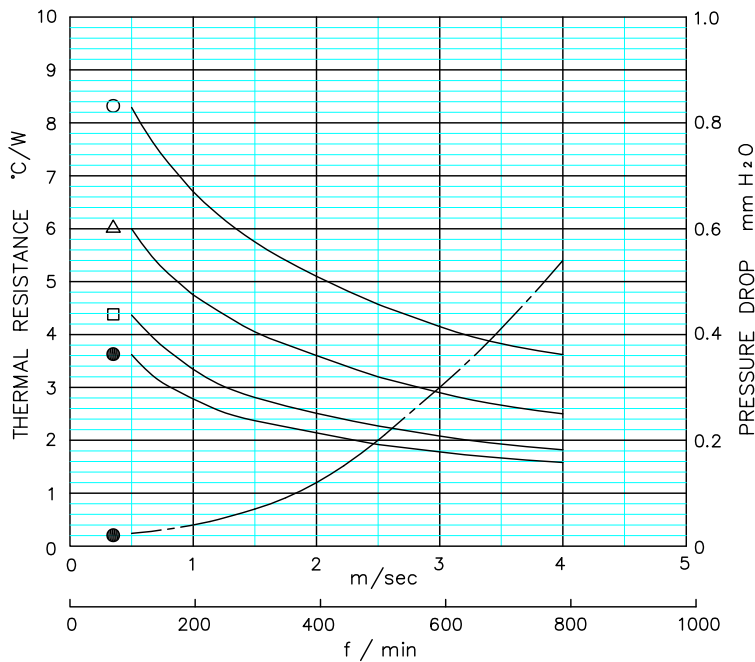

- DCC5923L-6B
- △ DCC5923L-11B
- DCC5923L-18B
- DCC5923L-23B

● DUCTED CONDITION  
 THERMAL RESISTANCE ———  
 PRESSURE DROP - - -

AIR VELOCITY: DUCTED CONDITION

■ BASED ON ALPHA'S STANDARD TEST PROCEDURE. REFER TO TECHNICAL INFORMATION.

Alpha Company Ltd.

256-1 UEDA, NUMAZU-CITY SHIZUOKA-PREF., JAPAN  
 PHONE +81(55)966 0789  
 FAX +81(55)966 9192  
 E mail : alpha@micforg.co.jp  
 URL : <http://www.micforg.co.jp>

Alpha Novatech, Inc. - a subsidiary of Alpha Company.

473 Sapena Ct. #12 Santa Clara, CA 95054 USA  
 PHONE +1(408)567-8082  
 FAX +1(408)567-8053  
 E mail : sales@alphanovatech.com  
 URL : <http://www.alphanovatech.com>

# ALPHA

Quarter Bricks  
Width 1.45"  
Length 2.28"

# DCC 3758 L

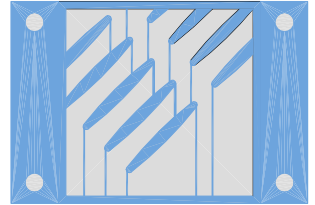

DIM

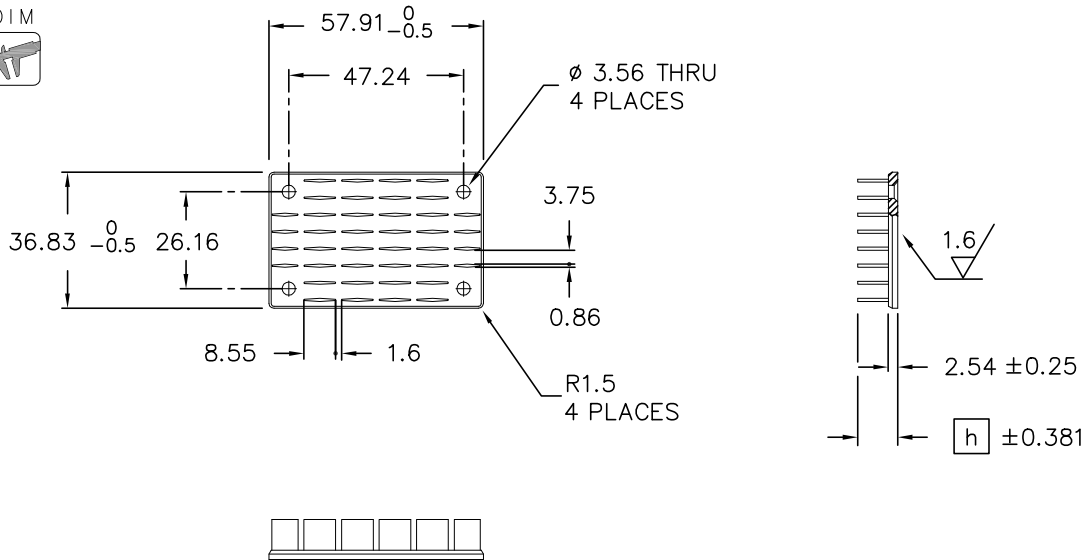

HEAT SINK  
MATERIAL : A 6063  
FINISH : BLACK ANODIZE

MODEL	HEIGHT $h$	WEIGHT (grams)
DCC3758L-11B	10.8	18.7
DCC3758L-18B	17.8	22.8
DCC3758L-23B	22.8	25.8

Dimensions : mm

DATA

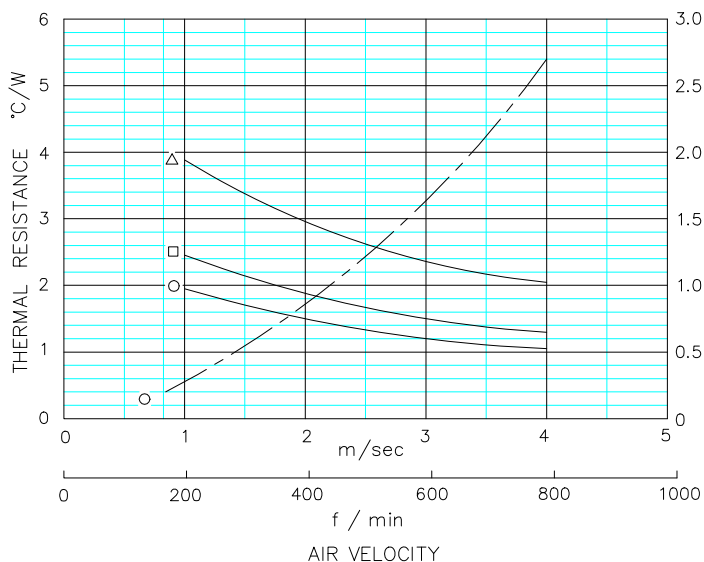

Alpha Company Ltd.

256-1 UEDA, NUMAZU-CITY SHIZUOKA-PREF., JAPAN  
PHONE +81(55)966 0789  
FAX +81(55)966 9192  
E mail : alpha@micforg.co.jp  
URL : <http://www.micforg.co.jp>

Alpha Novatech, Inc. - a subsidiary of Alpha Company.

473 Sapena Ct. #12 Santa Clara, CA 95054 USA  
PHONE +1(408)567-8082  
FAX +1(408)567-8053  
E mail : sales@alphanovatech.com  
URL : <http://www.alphanovatech.com>

# ALPHA

Quarter Bricks  
Width 1.45"  
Length 2.28"

# DCC 3758 U

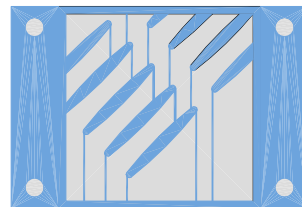

DIM

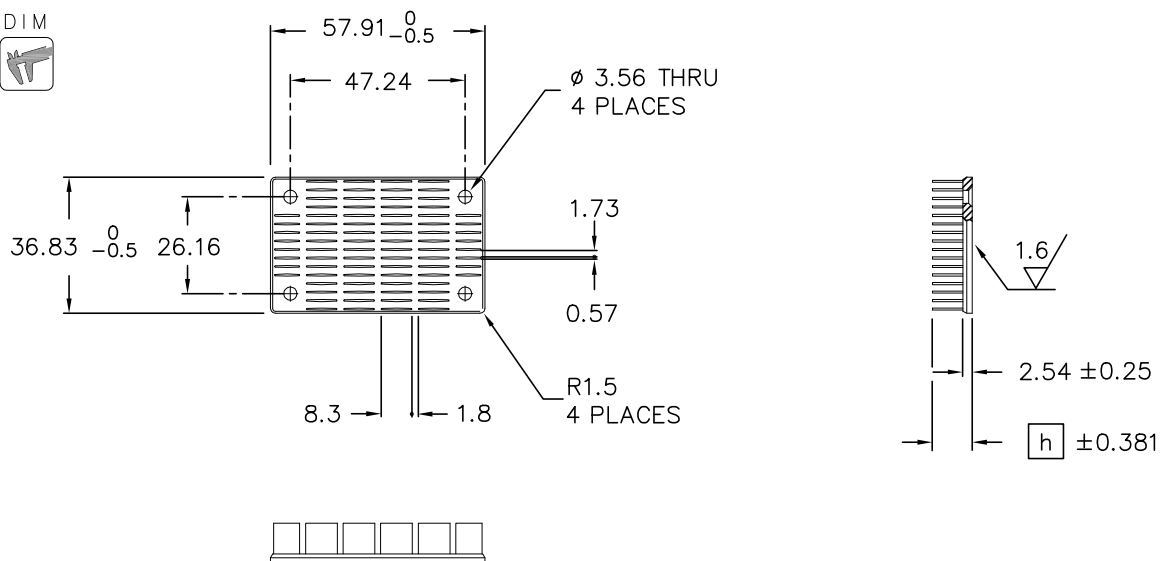

HEAT SINK  
MATERIAL : A 6063  
FINISH : BLACK ANODIZE

MODEL	HEIGHT $h$	WEIGHT (grams)
DCC3758U-11B	10.8	20.9
DCC3758U-18B	17.8	26.9
DCC3758U-23B	22.8	31.2

Dimensions : mm

DATA

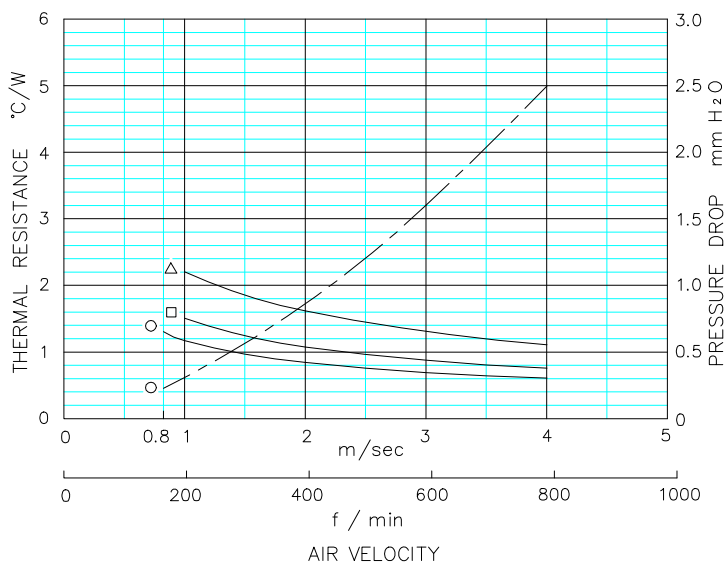

Alpha Company Ltd.

256-1 UEDA, NUMAZU-CITY SHIZUOKA-PREF., JAPAN  
PHONE +81(55)966 0789  
FAX +81(55)966 9192  
E mail : alpha@micforg.co.jp  
URL : <http://www.micforg.co.jp>

Alpha Novatech, Inc. - a subsidiary of Alpha Company.

473 Sapena Ct. #12 Santa Clara, CA 95054 USA  
PHONE +1(408)567-8082  
FAX +1(408)567-8053  
E mail : sales@alphanovatech.com  
URL : <http://www.alphanovatech.com>

# ALPHA

Quarter Bricks  
Width 2.28"  
Length 1.45"

# DCC5837L

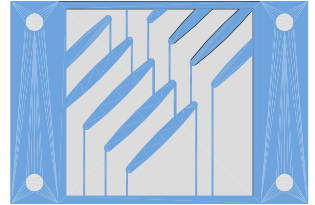

DIM

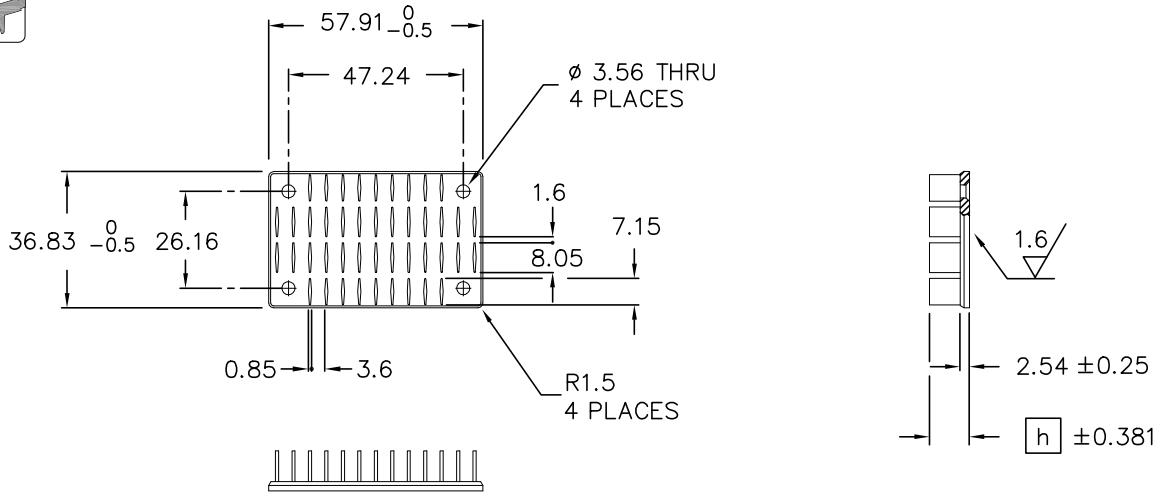

HEAT SINK  
MATERIAL : A 6063  
FINISH : BLACK ANODIZE

MODEL	HEIGHT $h$	WEIGHT (grams)
DCC5837L-11B	10.8	18.6
DCC5837L-18B	17.8	23.1
DCC5837L-23B	22.8	26.3

Dimensions : mm

DATA

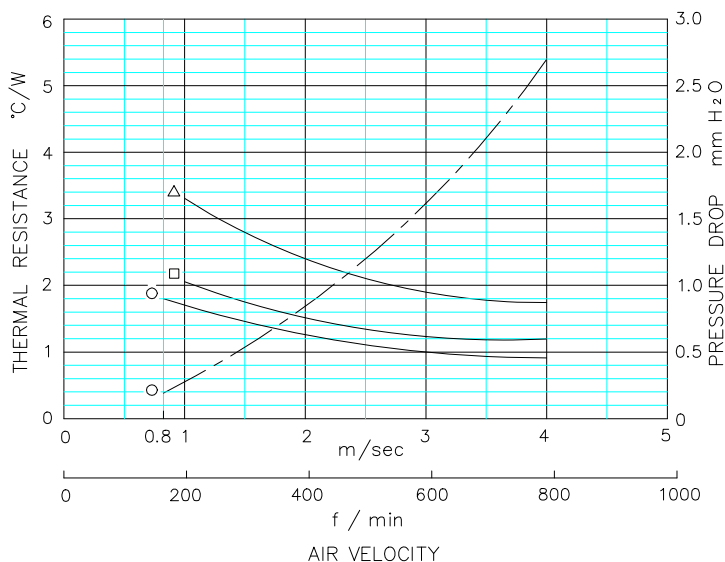

- Thermal Resistance ( Ducted )  
( Solid Line — )
- Pressure Drop  
( Center Line - - - )

- △ DCC5837L-11B
- DCC5837L-18B
- DCC5837L-23B

- Based on Alpha's Standard Test Procedure. (Refer to page marked Technical Information.)  
Dummy Heater Size: 35x56(mm)

Alpha Company Ltd.

256-1 UEDA, NUMAZU-CITY SHIZUOKA-PREF., JAPAN  
PHONE +81(55)966 0789  
FAX +81(55)966 9192  
E mail : alpha@micforg.co.jp  
URL : <http://www.micforg.co.jp>

Alpha Novatech, Inc. - a subsidiary of Alpha Company.

473 Sapena Ct. #12 Santa Clara, CA 95054 USA  
PHONE +1(408)567-8082  
FAX +1(408)567-8053  
E mail : sales@alphanovatech.com  
URL : <http://www.alphanovatech.com>

# ALPHA

Quarter Bricks  
Width 2.28"  
Length 1.45"

# DCC 5837 U

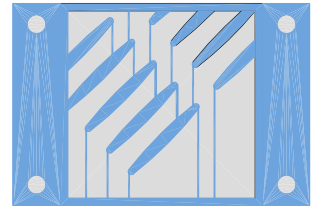

DIM

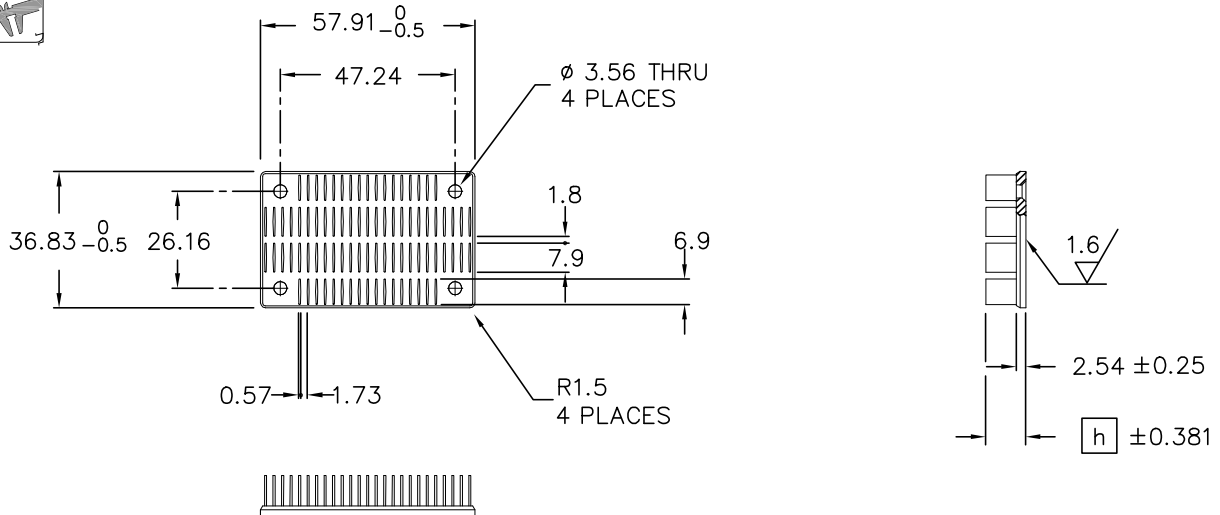

HEAT SINK  
MATERIAL : A 6063  
FINISH : BLACK ANODIZE

MODEL	HEIGHT [h]	WEIGHT (grams)
DCC5837U-11B	10.8	21.1
DCC5837U-18B	17.8	27.1
DCC5837U-23B	22.8	31.3

Dimensions : mm

DATA

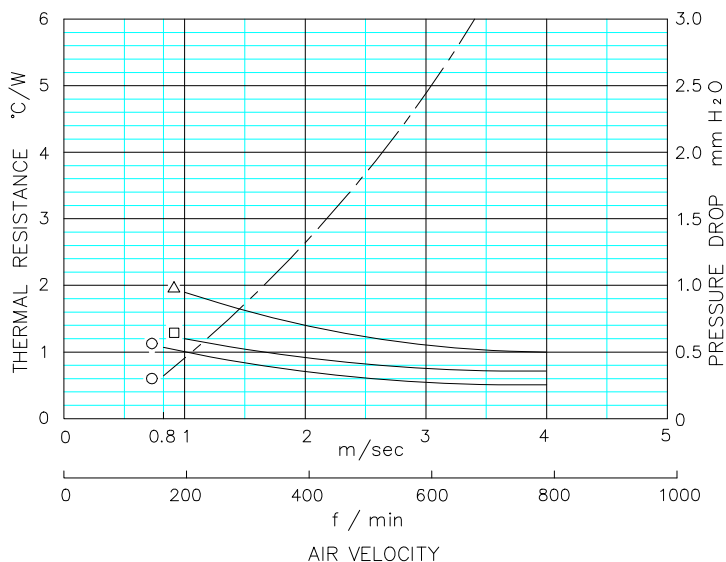

- Thermal Resistance ( Ducted )  
( Solid Line ——— )
- Pressure Drop  
( Center Line - - - - )

- △ DCC5837U-11B
- DCC5837U-18B
- DCC5837U-23B

- Based on Alpha's Standard Test Procedure. (Refer to page marked Technical Information.)  
Dummy Heater Size: 35x56(mm)

Alpha Company Ltd.

256-1 UEDA, NUMAZU-CITY SHIZUOKA-PREF., JAPAN  
PHONE +81(55)966 0789  
FAX +81(55)966 9192  
E mail : alpha@micforg.co.jp  
URL : http://www.micforg.co.jp

Alpha Novatech, Inc. - a subsidiary of Alpha Company.

473 Sapena Ct. #12 Santa Clara, CA 95054 USA  
PHONE +1(408)567-8082  
FAX +1(408)567-8053  
E mail : sales@alphanovatech.com  
URL : http://www.alphanovatech.com

# ALPHA

Half Bricks  
Width 2.35"  
Length 2.35"

# DCC 60 N

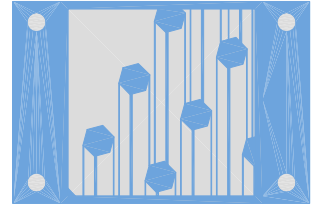

DIM

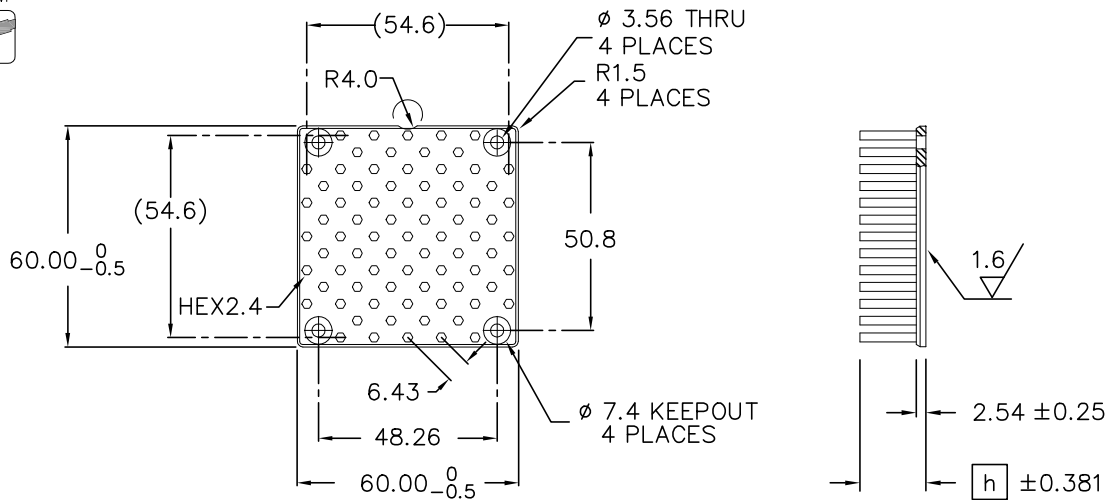

MODEL	HEIGHT $h$	WEIGHT (grams)
DCC60N-11B	10.8	33.1
DCC60N-18B	17.8	40.5
DCC60N-23B	22.8	45.8

HEAT SINK  
MATERIAL : A 6063  
FINISH : BLACK ANODIZE

FIN ARRANGEMENT MAY ROTATE 90 DEGREES.

Dimensions : mm

DATA

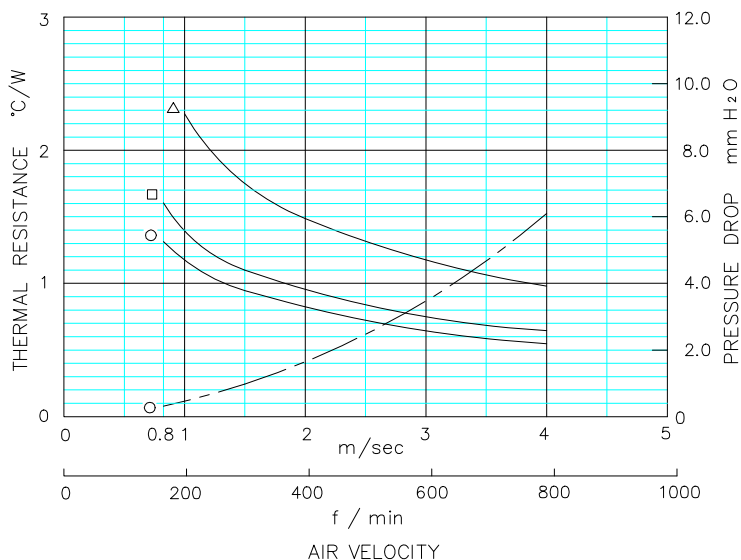

- Thermal Resistance ( Ducted )  
( Solid Line ——— )
- Pressure Drop  
( Center Line - - - )
- △ DCC60N-11B
- DCC60N-18B
- DCC60N-23B

■ Based on Alpha's Standard Test Procedure. (Refer to page marked Technical Information.)  
Dummy Heater Size: 55x58(mm)

Alpha Company Ltd.

256-1 UEDA, NUMAZU-CITY SHIZUOKA-PREF., JAPAN  
PHONE +81(55)966 0789  
FAX +81(55)966 9192  
E mail : alpha@micforg.co.jp  
URL : http://www.micforg.co.jp

Alpha Novatech, Inc. - a subsidiary of Alpha Company.

473 Sapena Ct. #12 Santa Clara, CA 95054 USA  
PHONE +1(408)567-8082  
FAX +1(408)567-8053  
E mail : sales@alphanovatech.com  
URL : http://www.alphanovatech.com



# ALPHA

Half Bricks  
Width 2.35"  
Length 2.35"

# DCC 60 S

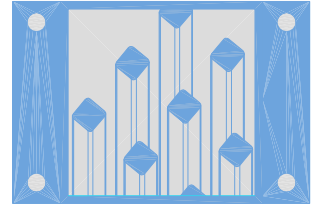

DIM

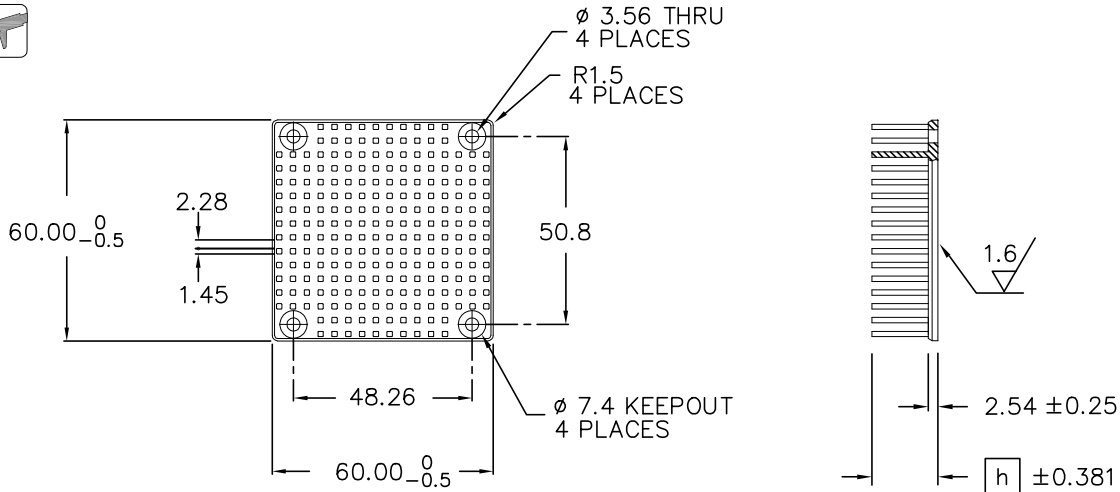

HEAT SINK  
MATERIAL : A 6063  
FINISH : BLACK ANODIZE

MODEL	HEIGHT $h$	WEIGHT (grams)
DCC60S-11B	10.8	35.2
DCC60S-18B	17.8	44.7
DCC60S-23B	22.8	51.4

Dimensions : mm

DATA

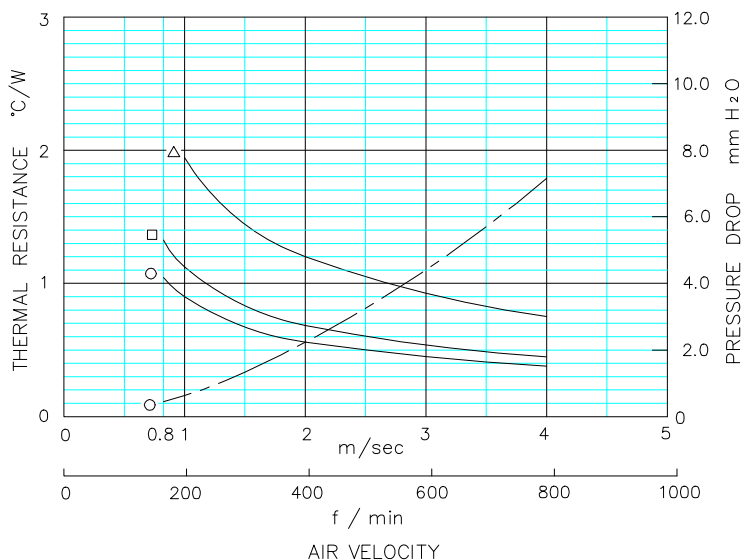

- Thermal Resistance ( Ducted )  
( Solid Line ——— )
- Pressure Drop  
( Center Line - - - )

- △ DCC60S-11B
- DCC60S-18B
- DCC60S-23B

- Based on Alpha's Standard Test Procedure. (Refer to page marked Technical Information.)  
Dummy Heater Size: 55x58(mm)

Alpha Company Ltd.

256-1 UEDA, NUMAZU-CITY SHIZUOKA-PREF., JAPAN  
PHONE +81(55)966 0789  
FAX +81(55)966 9192  
E mail : alpha@micforg.co.jp  
URL : <http://www.micforg.co.jp>

Alpha Novatech, Inc. - a subsidiary of Alpha Company.

473 Sapena Ct. #12 Santa Clara, CA 95054 USA  
PHONE +1(408)567-8082  
FAX +1(408)567-8053  
E mail : sales@alphanovatech.com  
URL : <http://www.alphanovatech.com>

# ALPHA

Half Bricks  
Width 2.35"  
Length 2.35"

# DCC60L-H

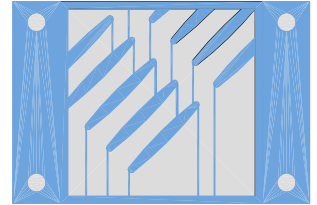

DIM

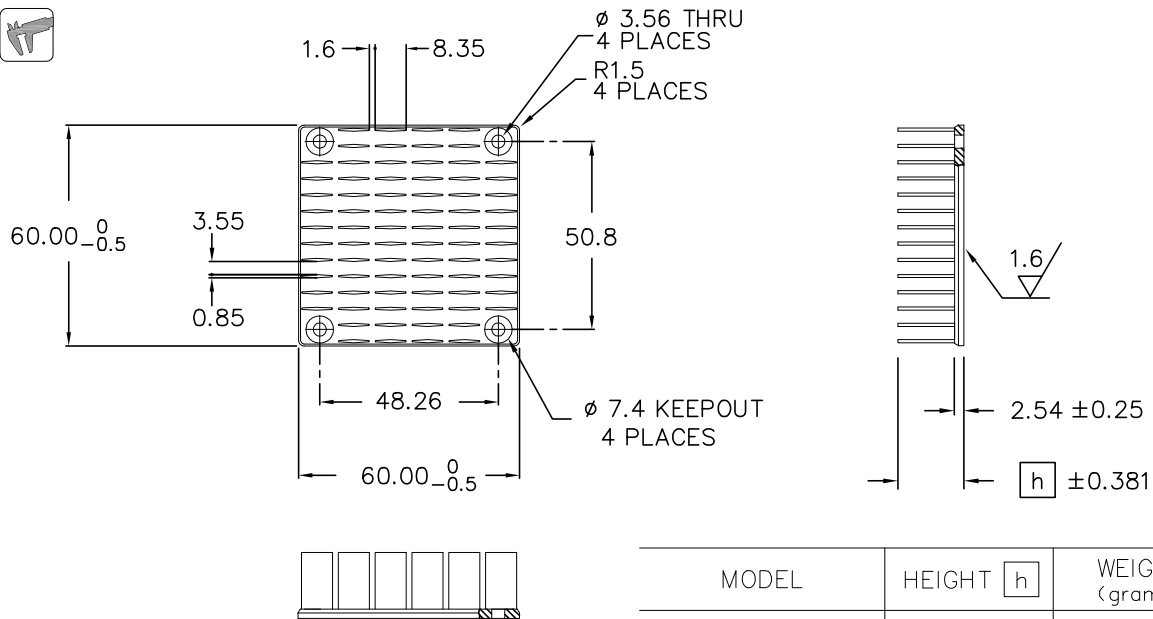

HEAT SINK  
MATERIAL : A 6063  
FINISH : BLACK ANODIZE

MODEL	HEIGHT $h$	WEIGHT (grams)
DCC60L-H11B	10.8	33.6
DCC60L-H18B	17.8	41.4
DCC60L-H23B	22.8	45.4

Dimensions : mm

DATA

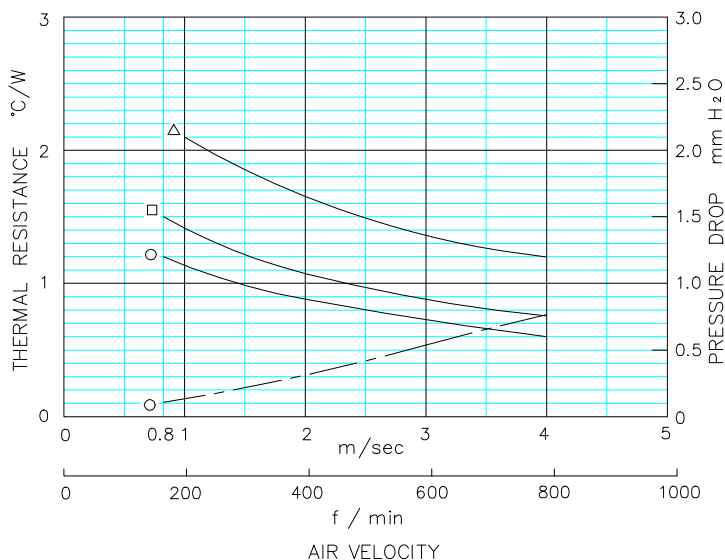

- Thermal Resistance ( Ducted )  
( Solid Line ——— )
- Pressure Drop  
( Center Line - - - )

- △ DCC60L-H11B
- DCC60L-H18B
- DCC60L-H23B

■ Based on Alpha's Standard Test Procedure. (Refer to page marked Technical Information.)  
Dummy Heater Size: 55x58(mm)

Alpha Company Ltd.

256-1 UEDA, NUMAZU-CITY SHIZUOKA-PREF., JAPAN  
PHONE +81(55)966 0789  
FAX +81(55)966 9192  
E mail : alpha@micforg.co.jp  
URL : http://www.micforg.co.jp

Alpha Novatech, Inc. - a subsidiary of Alpha Company.

473 Sapena Ct. #12 Santa Clara, CA 95054 USA  
PHONE +1(408)567-8082  
FAX +1(408)567-8053  
E mail : sales@alphanovatech.com  
URL : http://www.alphanovatech.com

# ALPHA

Half Bricks  
Width 2.35"  
Length 2.35"

# DCC60U-H

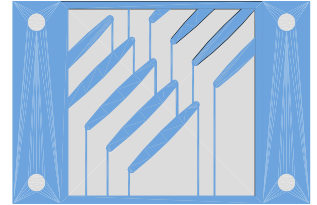

DIM

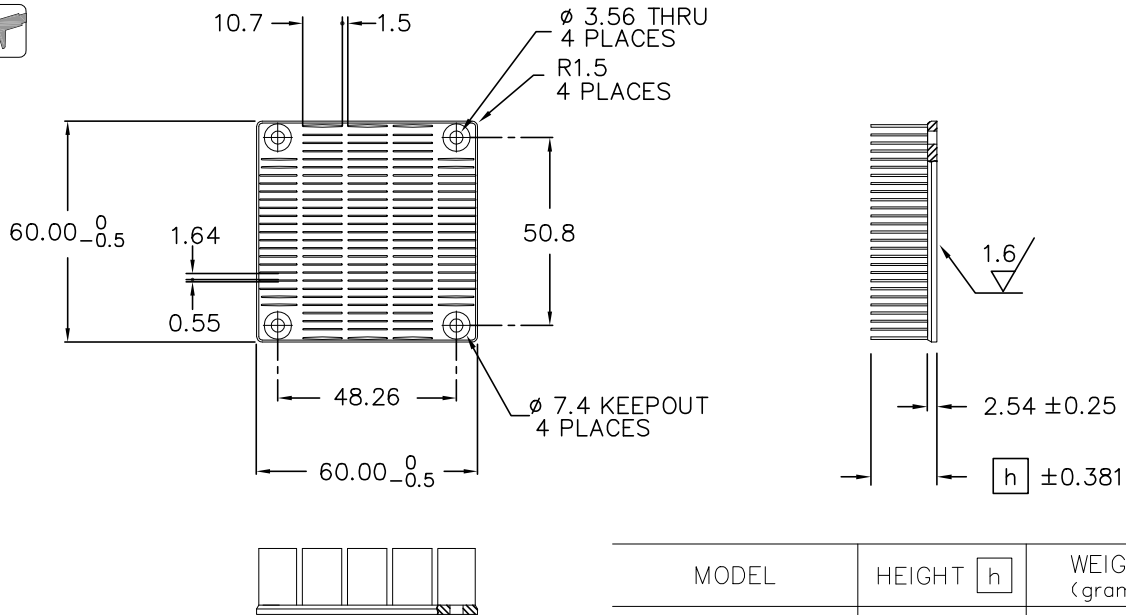

HEAT SINK  
MATERIAL : A 6063  
FINISH : BLACK ANODIZE

MODEL	HEIGHT [h]	WEIGHT (grams)
DCC60U-H11B	10.8	37.0
DCC60U-H18B	17.8	51.1
DCC60U-H23B	22.8	58.5

Dimensions : mm

DATA

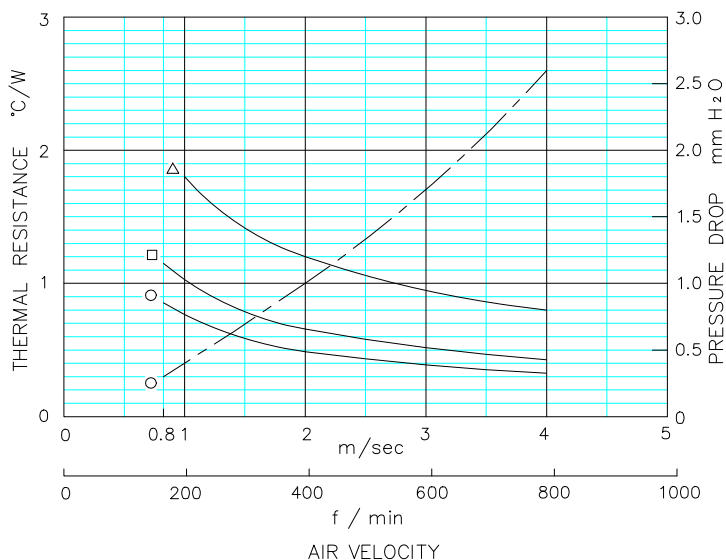

- Thermal Resistance ( Ducted )  
( Solid Line ——— )
- Pressure Drop  
( Center Line - - - )

- △ DCC60U-H11B
- DCC60U-H18B
- DCC60U-H23B

■ Based on Alpha's Standard Test Procedure. (Refer to page marked Technical Information.)  
Dummy Heater Size: 55x58(mm)

Alpha Company Ltd.

256-1 UEDA, NUMAZU-CITY SHIZUOKA-PREF., JAPAN  
PHONE +81(55)966 0789  
FAX +81(55)966 9192  
E mail : alpha@micforg.co.jp  
URL : http://www.micforg.co.jp

Alpha Novatech, Inc. - a subsidiary of Alpha Company.

473 Sapena Ct. #12 Santa Clara, CA 95054 USA  
PHONE +1(408)567-8082  
FAX +1(408)567-8053  
E mail : sales@alphanovatech.com  
URL : http://www.alphanovatech.com

# ALPHA

Half Bricks  
Width 2.35"  
Length 2.35"

# DCC60L-V

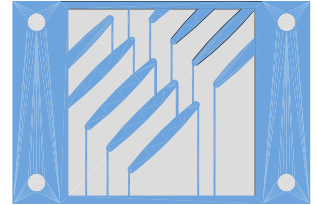

DIM

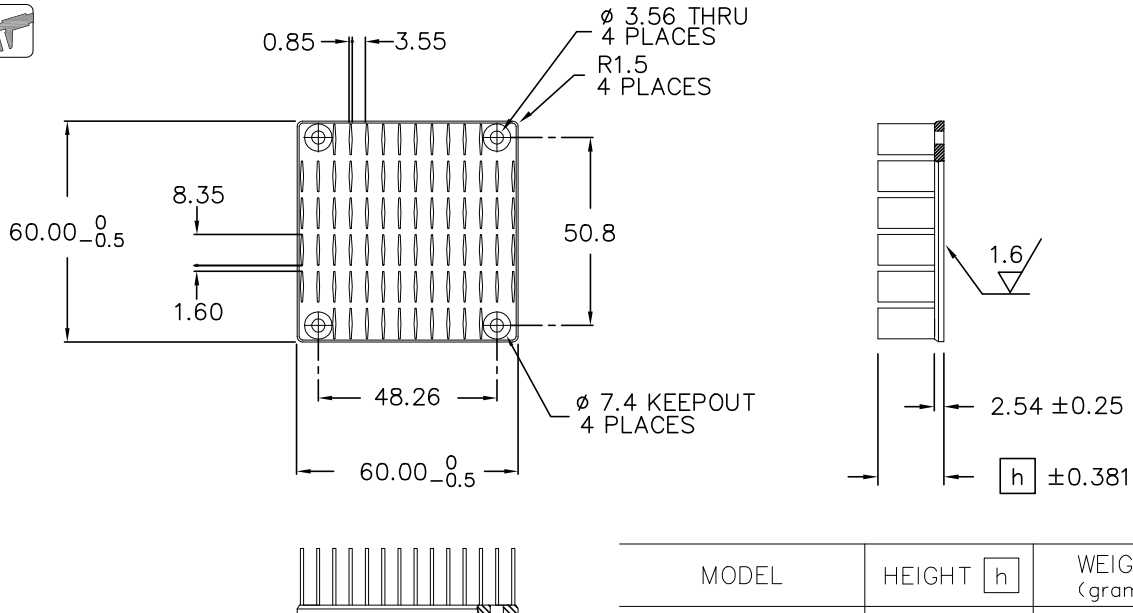

HEAT SINK  
MATERIAL : A 6063  
FINISH : BLACK ANODIZE

MODEL	HEIGHT $h$	WEIGHT (grams)
DCC60L-V11B	10.8	33.6
DCC60L-V18B	17.8	41.4
DCC60L-V23B	22.8	45.4

Dimensions : mm

DATA

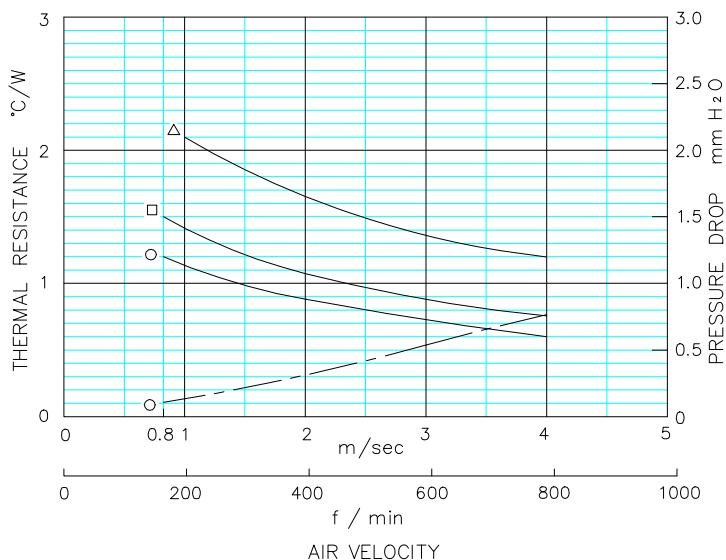

- Thermal Resistance ( Ducted )  
( Solid Line ——— )
- Pressure Drop  
( Center Line - - - )
- △ DCC60L-V11B
- DCC60L-V18B
- DCC60L-V23B

■ Based on Alpha's Standard Test Procedure. (Refer to page marked Technical Information.)  
Dummy Heater Size: 55x58(mm)

Alpha Company Ltd.

256-1 UEDA, NUMAZU-CITY SHIZUOKA-PREF., JAPAN  
PHONE +81(55)966 0789  
FAX +81(55)966 9192  
E mail : alpha@micforg.co.jp  
URL : http://www.micforg.co.jp

Alpha Novatech, Inc. - a subsidiary of Alpha Company.

473 Sapena Ct. #12 Santa Clara, CA 95054 USA  
PHONE +1(408)567-8082  
FAX +1(408)567-8053  
E mail : sales@alphanovatech.com  
URL : http://www.alphanovatech.com

# ALPHA

Half Bricks  
Width 2.35"  
Length 2.35"

# DCC 60U - V

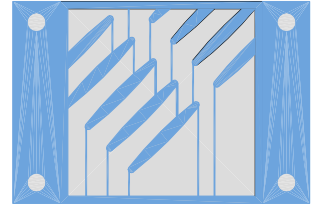

DIM

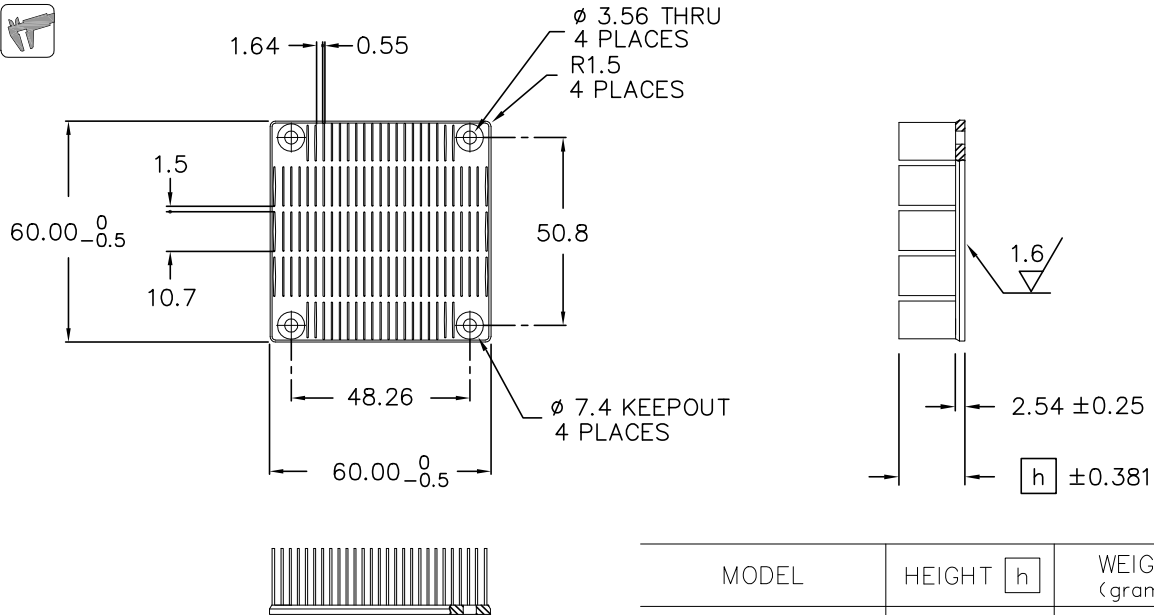

HEAT SINK  
MATERIAL : A 6063  
FINISH : BLACK ANODIZE

MODEL	HEIGHT $h$	WEIGHT (grams)
DCC60U-V11B	10.8	37.0
DCC60U-V18B	17.8	51.1
DCC60U-V23B	22.8	58.5

Dimensions : mm

DATA

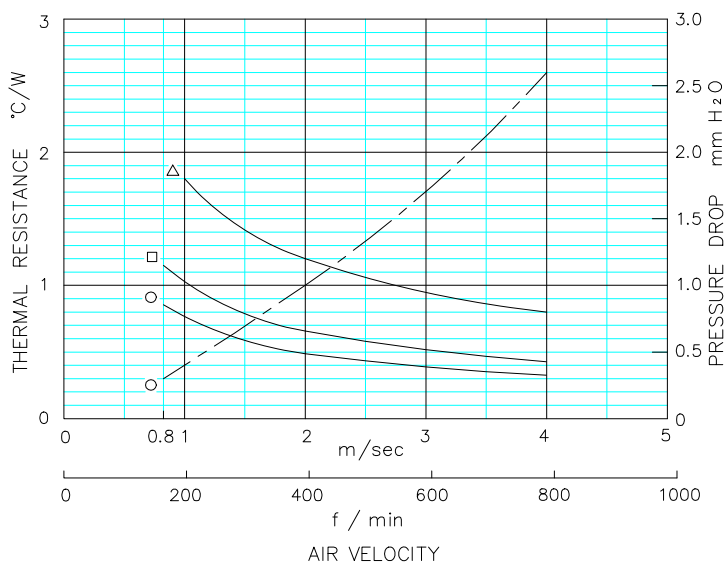

Alpha Company Ltd.

256-1 UEDA, NUMAZU-CITY SHIZUOKA-PREF., JAPAN  
PHONE +81(55)966 0789  
FAX +81(55)966 9192  
E mail : alpha@micforg.co.jp  
URL : <http://www.micforg.co.jp>

Alpha Novatech, Inc. - a subsidiary of Alpha Company.

473 Sapena Ct. #12 Santa Clara, CA 95054 USA  
PHONE +1(408)567-8082  
FAX +1(408)567-8053  
E mail : sales@alphanovatech.com  
URL : <http://www.alphanovatech.com>