

# ALPHA

## Active Heat Sink

# FH80

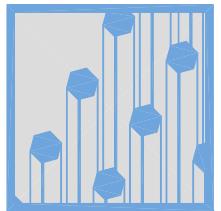

DIM

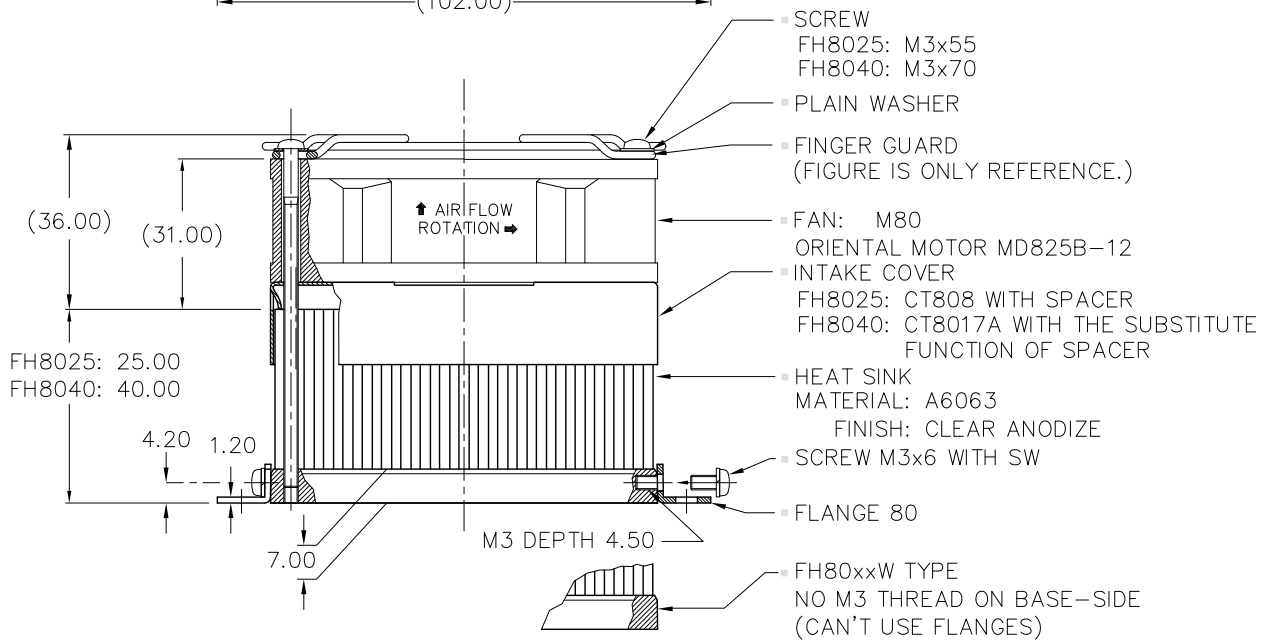
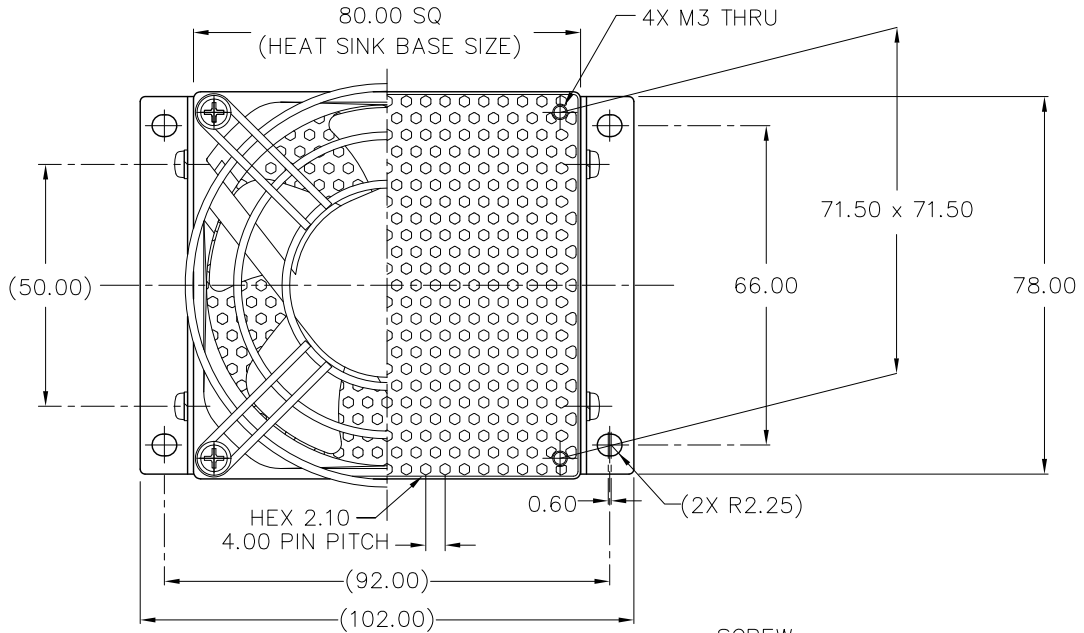

DIMENSIONS : mm

DATA



Model	Thermal Resistance (°C/W)	0	0.5	1.0
FH8025MU	0.24 °C/W	[Bar chart showing thermal resistance distribution]		
FH8040MU	0.16 °C/W	[Bar chart showing thermal resistance distribution]		

- TESTING SPECIFICATIONS DUMMY HEATER SIZE: 70SQ
- BASED ON ALPHA'S STANDARD TEST PROCEDURE. REFER TO TECHNICAL INFORMATION.

Alpha Company Ltd.

256-1 UEDA, NUMAZU-CITY SHIZUOKA-PREF., JAPAN  
 PHONE +81(55)966 0789  
 FAX +81(55)966 9192  
 E mail : alpha@micforg.co.jp  
 URL : http://www.micforg.co.jp

Alpha Novatech, Inc. - a subsidiary of Alpha Company.

473 Sapena Ct. #12 Santa Clara, CA 95054 USA  
 PHONE +1(408)567-8082  
 FAX +1(408)567-8053  
 E mail : sales@alphanovatech.com  
 URL : http://www.alphanovatech.com