

ALPHA

Copper Embedded Type

LC100

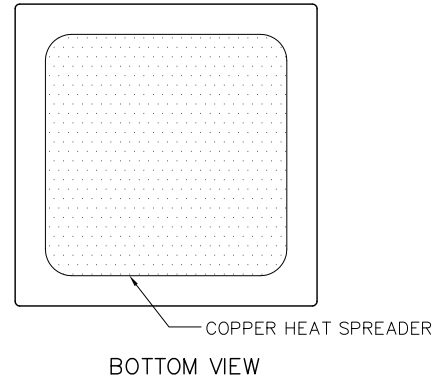
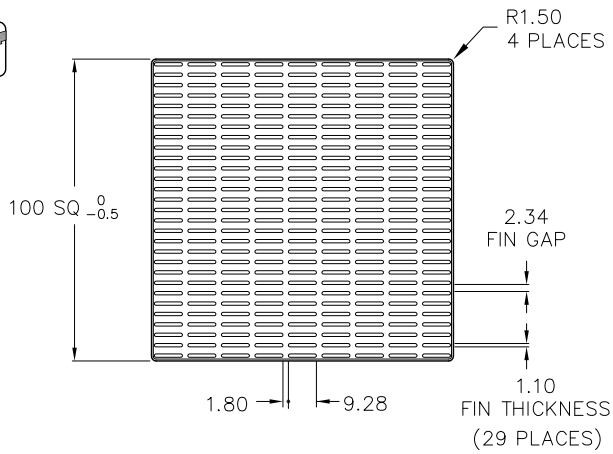
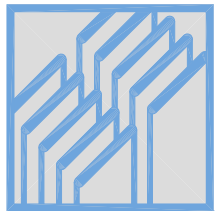

HEAT SINK
 MATERIAL : A 6063
 FINISH : BLACK ANODIZE
 (EXCEPT BOTTOM SURFACE)

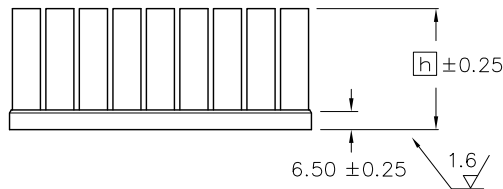

MODEL	HEIGHT h	WEIGHT (grams)
LC100-30B	30	445.5
LC100-40B	40	518.1

Dimensions : mm

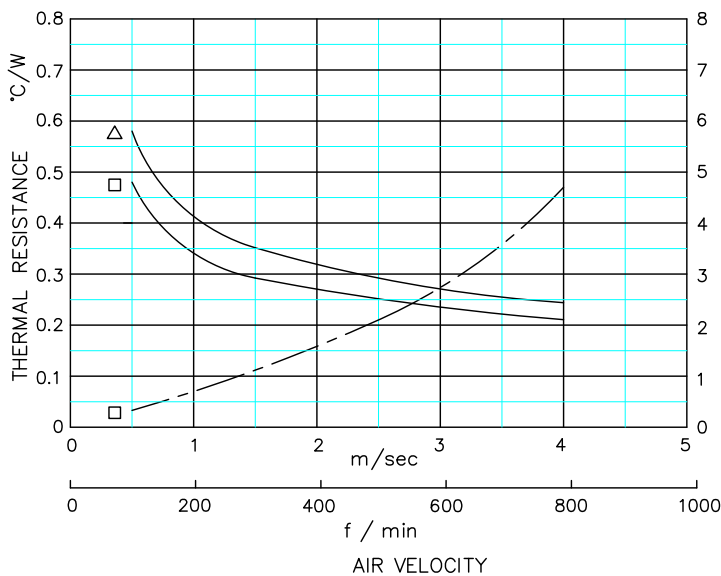

△ LC100-30B
 □ LC100-40B

● DUCTED CONDITION
 DUMMY HEATER SIZE: 25.4 SQ
 THERMAL RESISTANCE ———
 PRESURE DROP - - - -

■ BASED ON ALPHA'S STANDARD TEST PROCEDURE.
 REFER TO TECHNICAL INFORMATION.

Alpha Company Ltd.

256-1 UEDA, NUMAZU-CITY SHIZUOKA-PREF., JAPAN
 PHONE +81(55)966 0789
 FAX +81(55)966 9192
 E mail : alpha@micforg.co.jp
 URL : http://www.micforg.co.jp

Alpha Novatech, Inc. - a subsidiary of Alpha Company.

473 Sapena Ct. #12 Santa Clara, CA 95054 USA
 PHONE +1(408)567-8082
 FAX +1(408)567-8053
 E mail : sales@alphanovatech.com
 URL : http://www.alphanovatech.com