

REVISIONS				
REV	DATE	DESCRIPTION	CHG	APPR
PRODUCTION RELEASE				

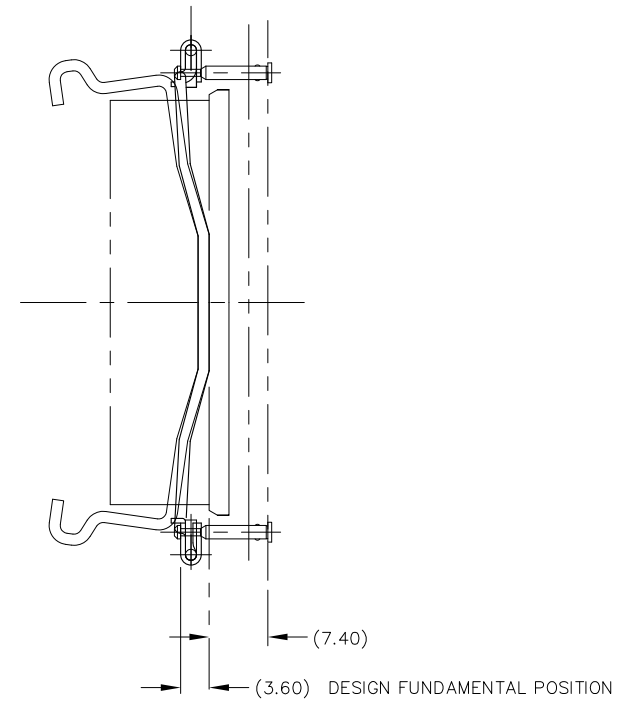
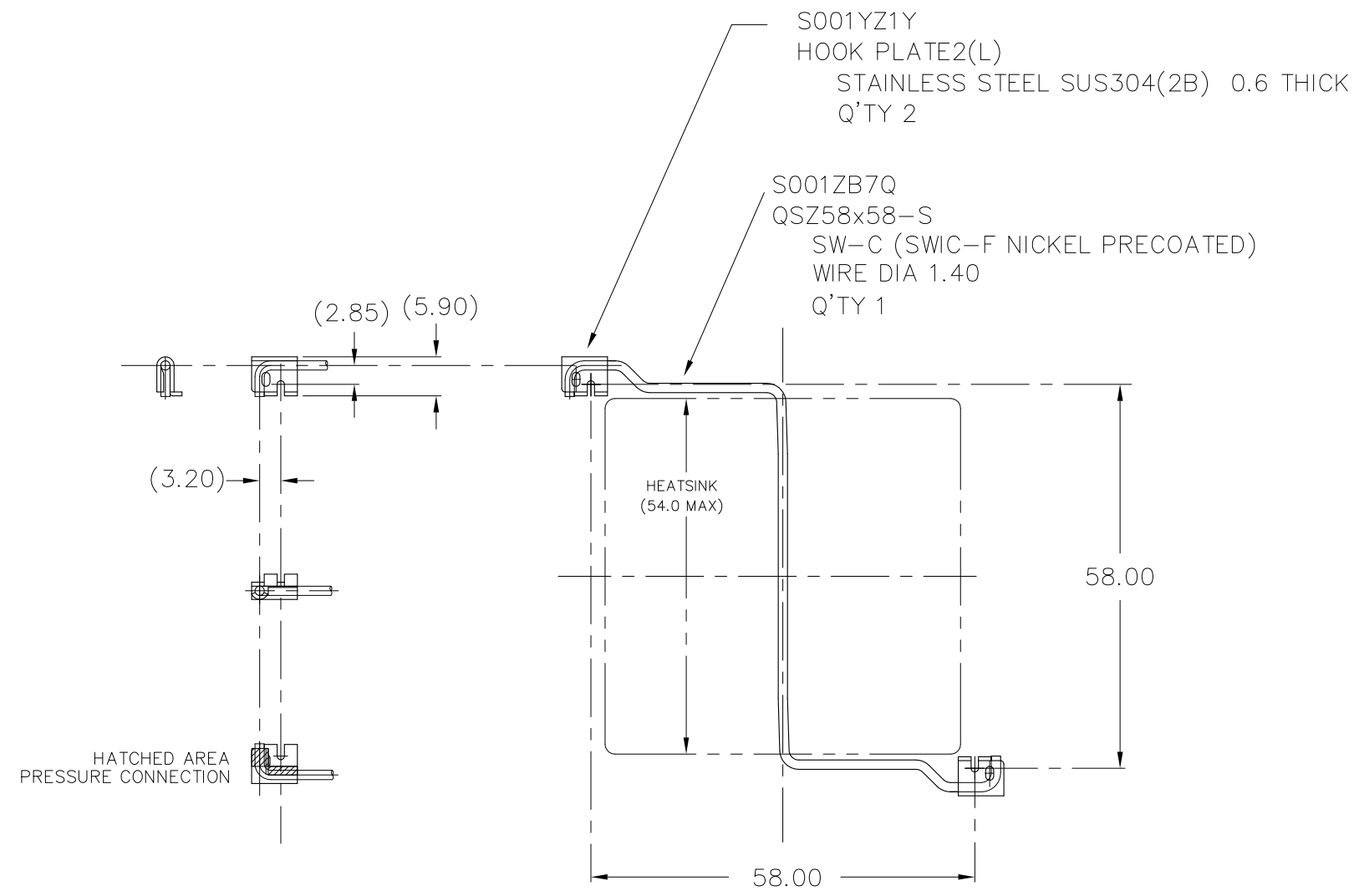

ANCHOR LAYOUT ON BOARD
REQUIRES $\phi 1.80 \pm 0.05$ THRU HOLES
FOR ANCHORS IN BOARD.

- NOTES : UNLESS OTHERWISE SPECIFIED
1. INTERPRET DIMENSIONS AND TOLERANCES PER ANSI Y14.5M
 2. ALL DIMENSIONS ARE IN MILLIMETERS.
 3. TOLERANCES :
 .XX ± 0.254
 .XXX ± 0.127
 ANGLES $\pm 3'$

ITEM	PART NO.	PART NAME	REMARK	Q'TY
ALPHA CO.,LTD.			CSTM'R'S PART NO.	
	MATERIAL		NAME QSZ58x58	
SCALE 1 : 1		APPR & CHCK Y.SUZUKI	PART NO. & DWG NO. S001ZB7P	
DATE JAN 14 2011		DSGN & DWG Y.SUZUKI	RDCTN:	LOFF: