

- NOTES : UNLESS OTHERWISE SPECIFIED
1. INTERPRET DIMENSIONS AND TOLERANCES PER ANSI Y14.5M
 2. ALL DIMENSIONS ARE IN MILLIMETERS.
 3. MATERIAL SW-C (SWIC-F NICKEL PRECOATED)
WIRE DIA 1.40
 4. TOLERANCES :
.XX ±0.254
.XXX ±0.127
ANGLES ± 3°
 5. INNER CORNER RADIUS 1.5

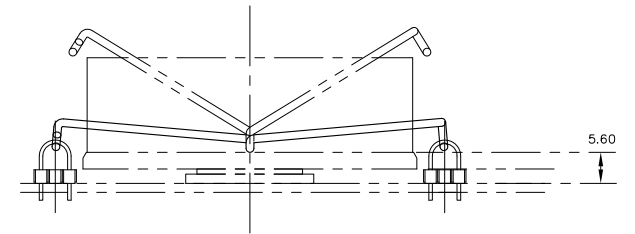
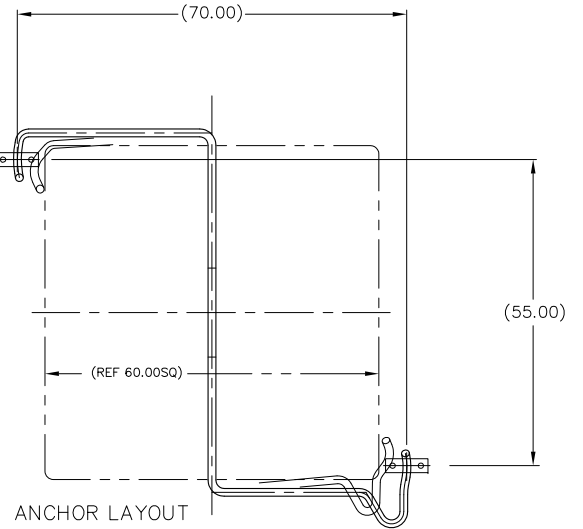
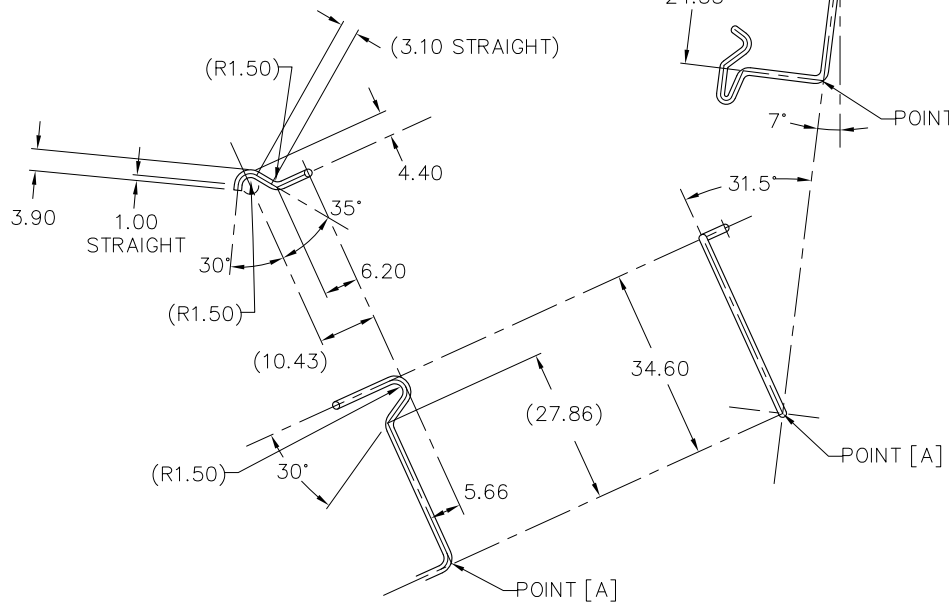
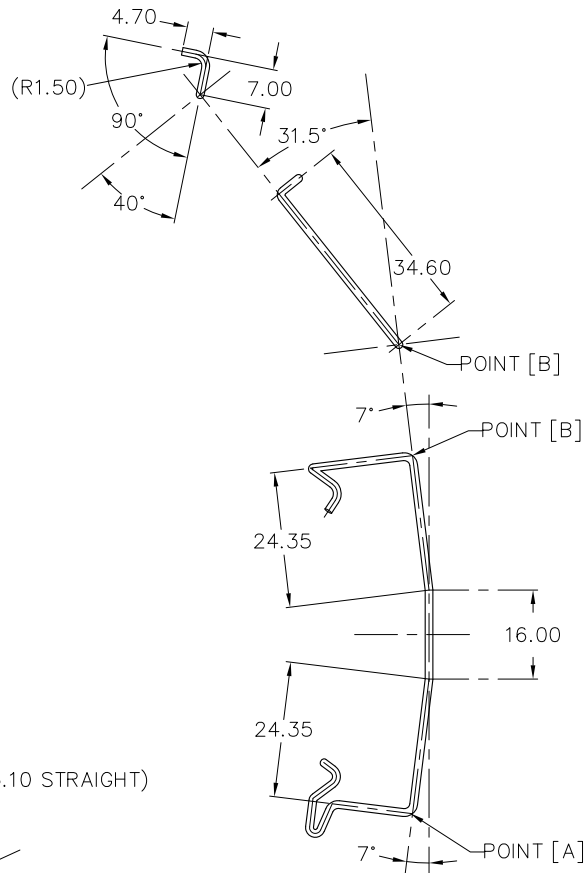

REVISIONS				
REV	DATE	DESCRIPTION	CHG	APPR

ITEM	PART NO.	PART NAME	REMARK	Q'TY
		ALPHA CO.,LTD.	CSTM'R'S PART NO.	
		MATERIAL SEE NOTE 3	NAME EZL-70x55	
SCALE 1 : 1		APPR & CHCK Y.SUZUKI	PART NO. & DWG NO. S001ZBG6	REV
DATE MAR 02 2017		DSGN & DWG Y.SUZUKI	RDCTN:	LOFF: