

REVISIONS				
REV	DATE	DESCRIPTION	CHG	APPR

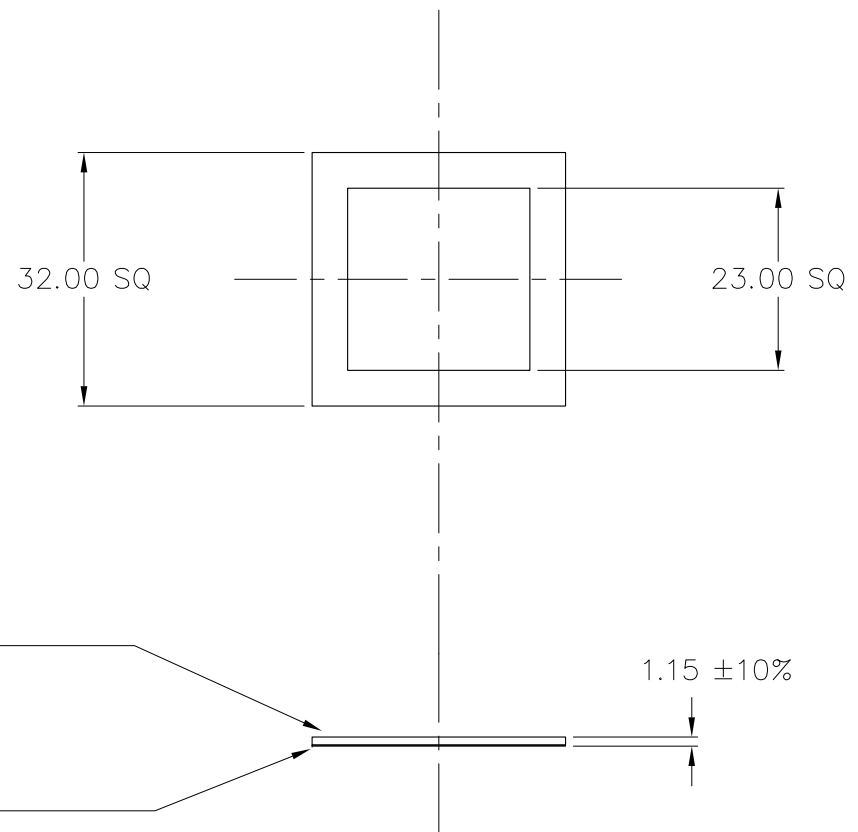

NOTES :

1. ALL DIMENSIONS ARE IN METRIC.

2. MATERIAL

URETHANES WITH THIN PET-FILM
INOAC CORP. PORON SR-U-40P
1.00 THICKNESS

ADHESIVE TAPE (PET SIDE OF SR-U-40P)
NITTO DENKO CORP. #5011N
0.15 THICKNESS
(SUPPLIED ON A REMOVABLE LINER.)

3. TOLERANCES : ±0.254

REFERENCE: PRESSURE - DEFLECTION

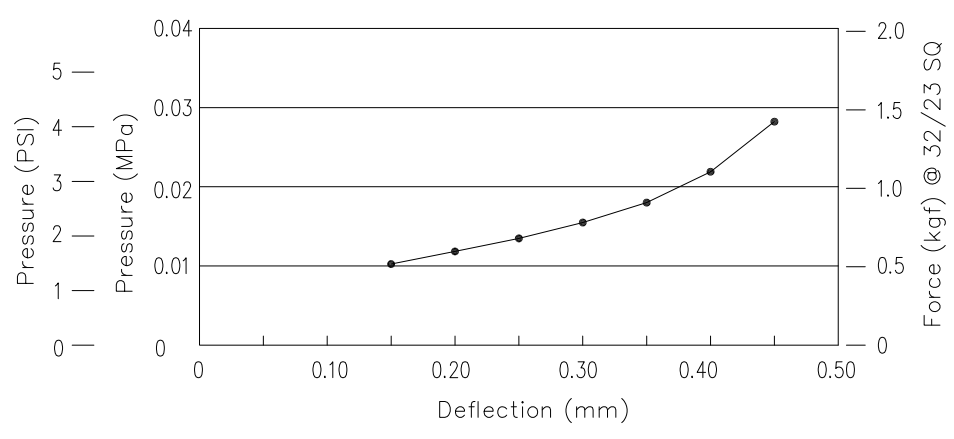

ITEM	PART NO.	PART NAME	REMARK	Q'TY
ALPHA CO.,LTD.		CSTMR'S PART NO.		
MATERIAL NOTE 2		NAME SP-32-23-1-SRU		
SCALE 1 : 1	APPR & CHCK Y. SUZUKI	PART NO. & DWG NO.		REV
DATE APR 07 2014	DSGN & DWG M. YAMAMOTO	S001ZW6F		
RDCTN:		LOFF:		