

REVISIONS				
REV	DATE	DESCRIPTION	CHG	APPR
/	AUG 23 '11	CRRCT THREAD UNDERCUT DIA (WAS 2.54 ±0.1). ADDED HEAD DIA TILERANCE	Y. S.	Y. S.
/	JAN. 07, '16	CHANGE PART NAME FROM SS-19.3 (4.78-M3-5)	T. Y.	T. Y.

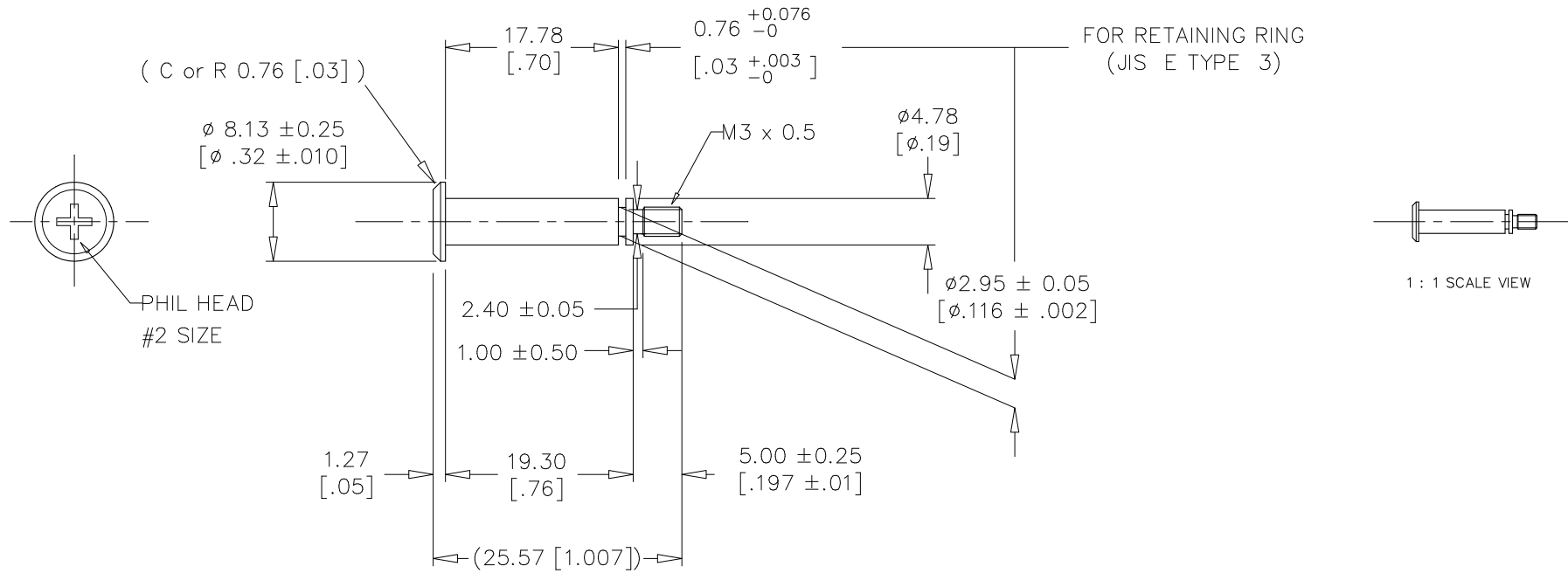

NOTES : UNLESS OTHERWISE SPECIFIED

- INTERPRET DIMENSIONS AND TOLERANCES PER ANSI Y14.5M
- ALL DIMENSIONS ARE IN MILLIMETERS [INCHES].
- MATERIAL
CARBON STEEL SWCH12A or EQUIVAIENT
ZINC /CLEAR CHROMATE (Cr3+)
- TOLERANCES : .X ±0.254 [.010]
.XX ±0.127 [.005]
- BREAK AND DEBUR ALL SHARP EDGES
- UNSPECIFIED RADII: 0.5 MAX
- MACHINED SURFACE FINISH TO BE $\sqrt{6.3}$ OR BETTER.

ITEM	PART NO.	PART NAME	REMARK	Q'TY
		ALPHA CO.,LTD.	CSTM'R'S PART NO.	
		MATERIAL NOTE 3	NAME SS-19.3-4.8-M3-5	
SCALE 2 : 1	APPR & CHCK Y.SUZUKI	PART NO. & DWG NO. S089HX0N	REV	
DATE JUL 15 2011	DSGN & DWG Y.SUZUKI	RDCTN:	LOFF:	